



Operating and Maintenance Instructions Manual

VE268 Pipe Roll Grooving Tool



! WARNING



Failure to follow Instructions and warnings can result in serious personal injury.

- Before installing, operating, or servicing this tool, read this Manual and all warning labels on the tool.
- Always wear safety glasses and foot protection.

If you need additional copies of the manual or have any questions about the safe operation of this tool, contact Victaulic Tool Company, P.O. Box 31, Easton, PA 18044-0031, Phone: 610-559-3300.

VE268

INDEX

Hazard Identification	3	Maintenance	28
Operator Safety Instructions	4	General	28
General	4	Lubrication	28
Tool Setup	4	Hydraulic Systems	29
Operating Tool	4	Gear Reducer Oil Level Check	32
Tool Maintenance	4	Recommended Lubricants	32
Introduction	5	Parts Ordering Information	32
Power Requirements	5	Accessories	33
Tool Nomenclature	6	Victaulic Adjustable Pipe Stands	33
Receiving Tool	7	Optional Rolls	33
Container Contents	7	Troubleshooting	34
Tool Setup	7	Electrical Schematic	36
Power Hook-Up	8	Tool Rating and Roll Selection	37
Pre-Operation Adjustments	9	Standard and "ES" Rolls	37
Grooving Rolls	9	Rolls for Stainless Steel (RX Rolls)	38
Pipe Preparation	9	Rolls for Copper Tubing	38
Groovable Pipe Lengths	9	Roll Groove Specifications	39
Roll Guard Adjustment	11	Steel Pipe and All Materials Grooved with Standard and RX Rolls	39
Pipe Stabilizer Adjustment	13	Drawn Copper Tubing	41
Groove Diameter Stop Adjustment/ Selector Valve Setting	15	Steel Pipe and All Materials Grooved with "ES" Rolls	42
Adjusting the Ram Speed Control Valve	16	Dimensions	43
Grooving Operation	17	Seamless and Welded Steel Pipe	43
Roll Changing	21	Drawn Copper Tubing	43

Hazard Identification

Definitions for identifying the various hazard levels shown on warning labels or to indicate proper safety procedures in this Manual are provided below.



This safety alert symbol indicates important safety messages on warning labels and in this manual. When you see this symbol be alert to the possibility of personal injury and carefully read and fully understand the message that follows.

! DANGER

The use of the word "DANGER" signifies an immediate hazard with a likelihood of serious personal injury or death if instructions, including recommended precautions, are not followed.

! WARNING

The use of the word "WARNING" signifies the presence of hazards or unsafe practices which could result in serious personal injury or death if instructions, including recommended precautions, are not followed.

! CAUTION

The use of the word "CAUTION" signifies possible hazards or unsafe practices which could result in minor personal injury, product or property damage if instructions, including precautions, are not followed.

NOTICE

The use of the word "NOTICE" signifies special instructions which are important but not related to hazards.

VE268

OPERATOR SAFETY INSTRUCTIONS

This tool is designed only for roll grooving pipe. To accomplish this function requires some dexterity and mechanical skills, as well as sound safety habits. Although this tool is manufactured for safe dependable operation, it is impossible to anticipate those combinations of circumstances which could result in an accident. The following instructions are recommended for safe operation of the tool. The operator is cautioned to always practice "Safety First" during each phase of use, including setup and maintenance of this unit. **It is the responsibility of the owner, lessee or user of this tool to ensure that all operators receive, read and understand this manual and are fully trained to operate this tool.**

GENERAL

- 1. Read and understand this Manual before operating or performing maintenance on this tool.** Become familiar with the tool's operations, applications and limitations. Be particularly aware of its specific hazards. Store this manual in a clean area and always at a readily available location. Additional copies at no charge are available upon request by writing or phoning the Victaulic Tool Company.
- 2. Use only recommended accessories.** Use of improper accessories may be hazardous. See Accessories on page 33.
- 3. This tool is designed ONLY for roll grooving of pipe sizes, materials and wall thicknesses outlined under Tool Rating and Roll Selection, pages 37 and 38.**

TOOL SETUP

- 1. Ground the machine.** VE268 components are all grounded to the tool frame. Be certain frame is properly grounded.
- 2. Avoid dangerous environments.** Don't use the machine in damp or wet locations. Don't use the tool on sloped or uneven ground or floor. Keep work area well illuminated. Allow sufficient space to operate tool and accessories properly and for others to pass safely.
- 3. Prevent back injury.** During tool setup, a lift must be used to handle and position tool.

OPERATING TOOL

- 1. Inspect the equipment.** Prior to starting the tool, check the movable parts for any obstructions. Be sure that guards and tool parts are properly installed and adjusted.
- 2. Prevent accidental startings.** Place power switch in the "OFF" position prior to connecting electrical power.
- 3. Operate with foot switch only.** The VE268 must be operated with a safety foot switch, located for easy operator access. The switch should always be accessible to the operator.
- 4. Keep hands away from grooving rolls and stabilizer wheel during grooving operation.** Grooving rolls can crush or cut fingers and hands.
- 5. Never reach inside pipe ends during operation.**
- 6. Do not over-reach.** Keep your proper footing and balance at all times. Be sure you can reach foot switch safely at all times. Do not reach across tool or pipe. Keep hands and loose tools away from moving parts.
- 7. Wear safety glasses and footwear.**
- 8. Keep work area clean.** Cluttered areas, benches and slippery floors invite accidents.
- 9. Wear ear protection if exposed to long periods of very noisy shop operations.**
- 10. Keep visitors away.** All visitors should be kept a safe distance from the work area.
- 11. Keep alert.** Do not operate tool if ill or drowsy from medication or fatigue. Avoid horseplay around tool and keep bystanders a safe distance from tool and pipe being grooved.
- 12. Wear proper apparel.** Never wear loose clothing (unbuttoned jackets or loose sleeve cuffs) loose gloves or jewelry that can get caught in moving parts.
- 13. Do not force tool.** It will do the job better and safer at the rate for which it was designed.
- 14. Secure work, tool and accessories.** Make sure tool is stable. See "Tool Setup" for securing to floor or platform.
- 15. Support work.** Support long pipe with a pipe stand secured to the floor or ground.
- 16. Do not misuse tool.** Perform only the functions for which the tool is designed. Do not overload the tool.

TOOL MAINTENANCE

- 1. Disconnect electrical power prior to servicing.** Repair should be attempted only by authorized personnel. Always disconnect power before servicing or making adjustments.
- 2. Maintain tool in top condition.** Keep tool clean for best and safest performance. Follow lubricating instructions.
- 3. Use only genuine Victaulic replacement parts to ensure proper and safe function of the tool.**

VE268

NOTICE

Drawings and/or pictures in this manual may be exaggerated for clarity.

INTRODUCTION

All Victaulic Vic-Easy® Series 268 tools are motorized semi-automated hydraulic feed tools for roll grooving of pipe to prepare it to receive Victaulic grooved pipe couplings. The VE268 is designed to roll groove pipe of various materials and wall thicknesses (see Tool Rating and Roll Selection charts on pages 37 and 38.)

This tool and manual contains trademarks, copyrights and/or patented features which are the exclusive property of Victaulic Company of America.

CAUTION

- This tool should be used only for roll grooving pipe designated in the Tool Rating and Roll Selection charts on pages 37 and 38.

Use of the tool for other purposes or exceeding the pipe thickness maximums will overload the tool, shorten tool life and may cause tool damage.

POWER REQUIREMENTS

The VE268 tools are designed to operate on 220 volt/440 volt, three phase, 60 Hertz power supply. The tool is shipped with wiring set for 220 volt operation unless otherwise specified on the order. To re-wire for 440 volt service refer to Electrical Schematic on page 36 and the drive motor name plate data. The 220 volt service requires a minimum of 20 amp circuit protection. VE268 components are all grounded to the tool frame. Be certain frame is properly grounded. For other voltages and frequencies, contact Victaulic Tool Company.

DANGER



- To reduce the risk of electric shock, check the electrical source for proper grounding.
- Before performing any repair or maintenance, disconnect the tool from the electrical source. Failure to do so could result in death or serious personal injury.

VE268

TOOL NOMENCLATURE

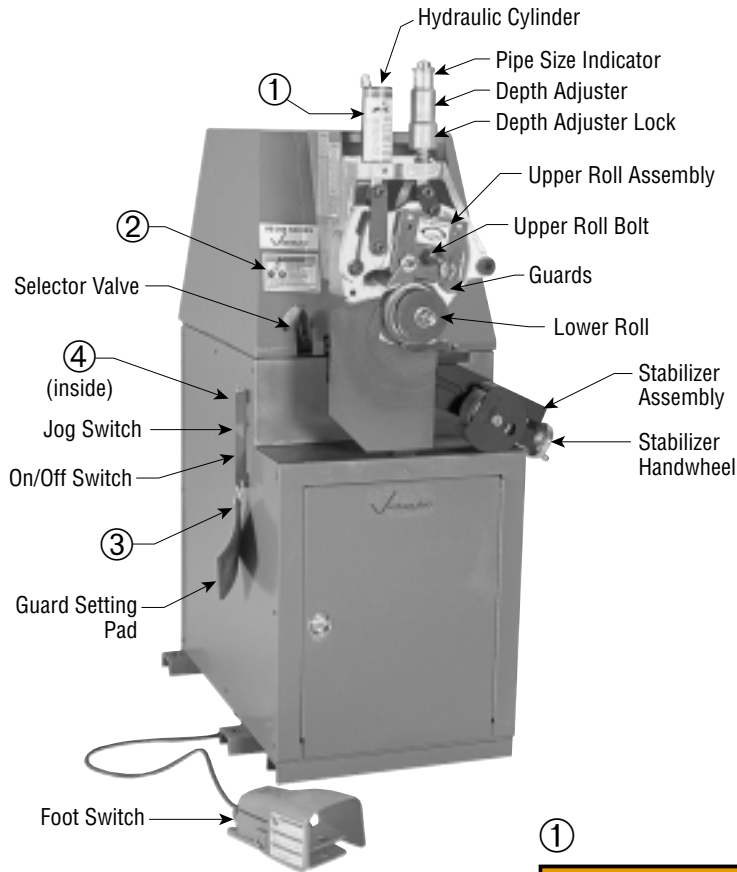

③
ALWAYS KEEP THIS PAD WITH THE TOOL. USE IT TO SET THE GUARDS IN ACCORDANCE WITH THE TOOL OPERATION AND MAINTENANCE MANUAL.
R068272LAB

④
⚠ DANGER
 Only Qualified Persons should open this door. Hazardous voltage inside will cause serious injury or death. ALWAYS disconnect power before servicing.
0531.12A7 R08042LAB 154

②
⚠ WARNING
Failure to follow instructions and warnings can result in serious injury, property damage, or faulty installation.

- Before installing, operating, or servicing this tool, read and understand the Operating Instructions and all warning labels on this tool.
- Always wear safety glasses and foot protection.

 If you have any questions about the safe operation of this tool, contact Victaulic Tool Company, P.O. Box 31, Easton, PA 18044-0031, 610-559-3300.
0567 Rev.A R031272LAB 3/99

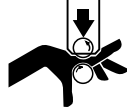
①
⚠ WARNING

Grooving rolls can crush or cut fingers and hands.

- Be sure guard is properly adjusted before grooving pipe.
- Keep hands away from grooving rolls and stabilizer wheel.
- Never reach inside pipe end or across the tool or pipe during operation.
- Always groove pipe in a clockwise direction only.
- Never groove pipe shorter than what is recommended.
- Never wear loose clothing, loose gloves, or jewelry while operating tool.

2246 Rev.A 2/98 R033274LB

VE268

RECEIVING TOOL

VE268 tools are palletized individually and covered with a cardboard sleeve, designed for use in reshipping tools.

NOTE: Be sure to save original shipping container for return shipment of rental tools.

VE268 CONTAINER CONTENTS

Upon receipt of tool, make sure all necessary parts are included. If any parts are missing, notify your Victaulic distributor or Victaulic representative.



1. Tool Assembly.
2. Rolls for 1 - 1½", 2 - 3½", 4 - 6" and 8 - 12" steel pipe. The 8 - 12" rolls are mounted on the head assembly.
3. Two (2) tool operating manuals.
4. Guard setting pad.
5. Lower roller removal wedge.
6. Aluminum hand knob.
7. Spare Woodruff keys
8. Bleeder Hose
9. One (1) 11 oz. can of Dow-Corning G-n Mechanical Assembly Spray

The standard Series VE268 tools are supplied with grooving rolls for 1 - 12" carbon steel pipe. Rolls are marked with the size and part number and color coded for pipe material, for your convenience. For grooving to other specifications and other materials, see Tool Rating and Roll Selection charts on pages 37 and 38. Grooving rolls for other specifications, sizes and other materials must be purchased separately.

TOOL SETUP

⚠ WARNING

- Do not connect power until instructed otherwise. Accidental start up of tool may result in serious personal injury.

All Series VE268 tools are shipped pre-assembled for shop or field setup. The tool should be placed on level ground, and must be secured to the floor or a platform secured to the floor.

⚠ WARNING

- During tool setup, one person cannot safely handle the tool because it weighs 685 lbs. A fork truck or hoist is needed to safely lift the tool into position. Failure to follow this instruction may result in serious personal injury.

1. Remove all components from the containers and check to be certain all necessary items are included. See "Receiving Tool."



2. The VE268 is designed to be used in a permanent location. It should be located on a level concrete floor or base. Once located, it should be leveled and securely anchored (see Figure 1, page 8), in a level position. A non-level tool can severely affect proper grooving operation. When checking tool levelness, place level directly on tool frame as shown above. The choice of tool location and position should take into account the following factors:

- a. Pipe handling and support requirements
- b. Power supply requirements
- c. Ambient temperature requirements: 20°F to 104°F

VE268

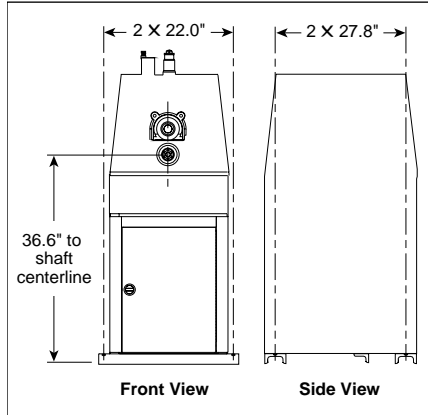

Figure 1
MOUNTING HOLE LOCATIONS
 (Four 3/16" / 14 mm diameter through holes)

POWER HOOK-UP

The tool is supplied with a #12/4 line cord (3 power, 1 ground). The tool is supplied set up for 220 volt, 3 phase, 60 Hz power unless specified otherwise. If 440 volt is to be used, be sure proper conversions are made. Conversions include: 1) motor connections; 2) fuse changes; 3) thermal unit overload changes and 4) transformer connections.

Consult Electrical Schematic on page 36 for information.

Once power is properly connected, the tool must be checked for proper rotational direction. Proceed as follows:



1. Turn main power switch "ON". It is located on the left-hand side of the tool.



2. Depress foot switch and observe the tool's lower roll rotation direction and then release foot switch.



3. Proper roll rotation is clockwise. If clockwise, power hook-up is complete and you should proceed to Pipe Preparation on page 9. If counterclockwise, turn main power switch off and proceed as follows:

- a.** Disconnect power.
- b.** Reverse any two (2) of three (3) power leads at the power source.
- c.** Turn main power switch "ON" and retest rotational direction. It should now be clockwise. If not, consult the Victaulic Tool Company.

⚠ DANGER



• ONLY QUALIFIED ELECTRICIANS SHOULD CONNECT OR DISCONNECT INCOMING POWER TO TOOL.

Failure to do so could result in death or serious personal injury.

VE268

PRE-OPERATION ADJUSTMENTS

Every Vic-Easy tool is checked, adjusted and tested at the factory prior to shipment. Before grooving, however, the following adjustments must be made in sequence to make sure of proper tool operation.

WARNING

- Always turn off power before making any tool adjustments unless instructed otherwise.
- Accidental start up of tool may result in serious personal injury.

GROOVING ROLLS

Make sure the proper roll set is on the tool for the pipe size and material to be grooved. They are marked with the pipe size, part number and color coded for the pipe material to be grooved. See Tool Rating and Roll Selection charts on pages 37 and 38. If proper rolls are not on tool, refer to Roll Changing on page 21.

CAUTION

- Make sure roll retaining bolts and nuts are tight. Loose retaining bolts or nuts could seriously damage both the tool and rolls.

PIPE PREPARATION

For proper tool operation, and production of proper pipe grooves, carefully observe the following pipe preparation tips.

1. Pipe ends should be cut squarely in accordance with Column 2 note on appropriate Roll Groove Specification chart, pages 39 - 42.
2. Internal or external weld bead or seams must be ground flush with the pipe surface extending 2" back from the pipe end.
3. The end of the pipe, both inside and out, must be cleaned of loose rust, coarse scale, dirt and other foreign material.

CAUTION

- For maximum grooving roll life, remove foreign material and loose rust.
- Foreign material such as coarse scale or dirt might interfere with or damage the grooving rolls or distort the groove. Rust is an abrasive material and will tend to wear out the surface of the grooving rolls.

4. Victaulic recommends that pipe shall be square ended. When using beveled pipe, standard wall or less, the bevel should not exceed 37½°. Square ended pipe must be used with FlushSeal® and EndSeal® gaskets. For heavier pipe walls, square ended pipe is required.

GROOVABLE PIPE LENGTHS

The VE268 is capable of grooving short pipe lengths without the use of a pipe stand (see Table 1, below), or long pipe lengths up to double randoms (approximately 40 ft.), with the use of appropriate stands.

SHORT PIPE LENGTHS

Table 1 shows minimum and maximum pipe lengths that can be grooved without the need for a pipe stand. Refer to Grooving Operation on page 17 for instructions on how to groove short pipe lengths. For pipe longer than shown in Table 1, refer to Long Pipe Lengths, page 10.

WARNING

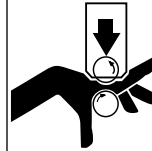

Grooving rolls can crush or cut fingers and hands.

- Loading and unloading pipe will place your hands close to the rollers.
- Never groove pipe shorter than what is recommended in Table 1 below.

TABLE 1
VE268 GROOVABLE PIPE LENGTHS

2468-1A

SIZE Nominal In. Actual mm	DIMENSIONS – (Inches/mm)	
	Min. Length	Max. Length
¾ 26.7	8 203.2	36 914.4
1 33.4	8 203.2	36 914.4
1¼ 42.2	8 203.2	36 914.4
1½ 48.3	8 203.2	36 914.4
2 60.3	8 203.2	36 914.4
2½ 73.0	8 203.2	36 914.4
3 88.9	8 203.2	36 914.4
3½ 101.6	8 203.2	36 914.4
4 114.3	8 203.2	36 914.4

Table continued on page 10.

VE268

TABLE 1
VE268 GROOVABLE PIPE LENGTHS

2468-1A

SIZE Nominal In. Actual mm	DIMENSIONS – (Inches/mm)	
	Min. Length	Max. Length
4½ 127.0	8 203.2	32 812.8
5 141.3	8 203.2	32 812.8
6 O.D. 152.4	10 254.0	30 762.0
6 168.3	10 254.0	28 711.2
8 O.D. 203.2	10 254.0	24 609.6
8 219.1	10 254.0	24 609.6
10* 273.0	10 254.0	20 508.0
12* 323.9	12 304.8	18 457.2

*For Schedule 30 and standard wall steel/stainless steel pipe, a pipe stand must be used on 10" NPS pipe nipples that are 15" and longer. Likewise, a pipe stand must be used on 12" NPS Schedule 30 and standard wall steel/stainless steel pipe nipples that are 14" and longer.

If a pipe shorter than the minimum shown in Table 1 is needed, if possible, shorten the next to last piece of pipe enough so that the last piece of pipe is as long or longer than the minimum length specified in Table 1. See example below.

NOTICE

Pipe nipples shorter than those shown in Table 1 are available from Victaulic.

Example: A 20' 4" length of 10" diameter pipe is needed to finish a section and you only have 20' lengths available. Instead of roll grooving a 20' piece of pipe and a 4" piece of pipe, follow these steps:

1. Refer to Table 1 and note that for 10" diameter pipe, the minimum length that should be grooved is 10".
2. Roll groove a 19' 6" piece of pipe and a 10" piece of pipe. Refer to Long Pipe Lengths below.

LONG PIPE LENGTHS

With pipe in excess of the maximum length shown in Table 1 (on page 9), a roller type pipe stand must be used.

NOTICE

Figure 2 below shows the Victaulic adjustable pipe stand (VAPS 112). VAPS 112 is suitable for ¾" to 12" pipe. Also available is Victaulic model VAPS 224 suitable for sizes 2" to 24". See Accessories on page 33.

1. Position pipe and pipe stand in accordance with Figures 2 and 3.

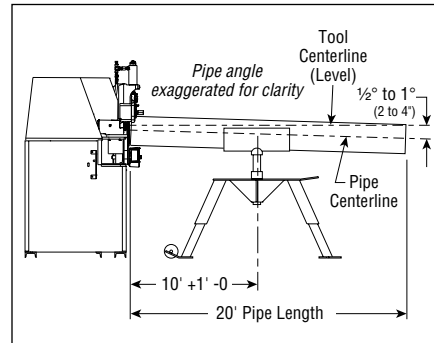

Figure 2
SUPPORT OF PIPE

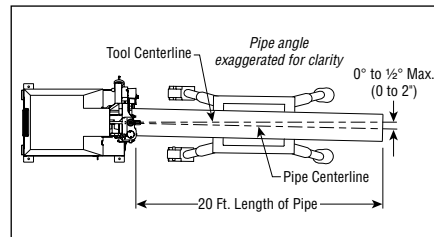

Figure 3
TRACKING ANGLE

WARNING

- Pipe stand location will affect pipe tracking.
- Incorrect pipe stand position may result in pipe being pushed out of rolls and falling.

Failure to position pipe and pipe stand in accordance with Figures 2 and 3 (shown above) may result in serious personal injury or property damage.

VE268

CAUTION

Pipe position will affect pipe flare.

- When pipe end flare is excessive, right-to-left tracking must be kept to a minimum. It may be necessary to use less than ½ degree.

Make sure tool is level (see Tool Setup).

- If pipe is grooved with back end of pipe (end of pipe which is not in tool) higher than the end being grooved, pipe may not track and excessive pipe end flare may result.
- Assembly of couplings on pipe exceeding Maximum Allowable Flare, Column 8 in the Roll Groove Specifications charts, pages 39 - 42, may prevent closure of couplings pad-to-pad, allowing possible pipe separation, and result in property damage.
- Also, joint leakage may result due to excessive gasket distortion/damage.

NOTICE

For additional information about pipe stands, refer to the Operating Instructions included with your pipe stand.

ROLL GUARD ADJUSTMENT

The VE268 guards must be adjusted every time rolls are changed or pipe size or wall thickness is different from previous pipe grooved.



1. Make sure the proper roll set is on the tool for the pipe size and material to be grooved. Rolls are marked with the pipe size, part number and are color coded for pipe material for your convenience. See Tool Rating and Roll Selection charts, pages 37 and 38. If the proper rolls are not on the tool, refer to Roll Changing on page 21.



2. Loosen wing nuts and move the adjustable guards to the full up position. Tighten wing nuts.



3. Set groove diameter stop to pipe size and schedule/thickness to be grooved. To do this, back off the depth adjuster lock, align the depth adjuster with the proper diameter and thickness. Lock the depth adjuster in position with the depth adjuster lock. See Groovable Pipe Lengths instructions and cautionary information on pages 9 - 11.



4. Retract stabilizer, if necessary, to insert pipe. To do this, loosen locking handle and retract stabilizer roller with the handwheel and retract pipe when inserted onto lower roll.

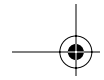

VE268



5. Insert a piece of pipe of the correct size and schedule/thickness to be grooved over the lower roll with the pipe end against the lower roll backstop flange. See Pipe Preparation on page 9.

WARNING

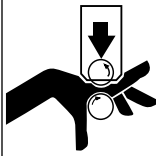

Grooving rolls can crush or cut fingers and hands.

- Loading and unloading pipe will place your hands close to the rollers.
- Never groove pipe shorter than what is recommended in Table 1 on page 9.



7. With operator on the switch side of the machine, use the safety foot switch to energize the tool motor, bringing the upper roll down into firm contact with pipe. Withdraw foot from safety foot switch.



8. Remove the guard setting pad from its storage hook. Hold the guard setting pad firmly down against the pipe and push it under the adjustable guards flush against the red plate.



6. Set the main power switch to the "ON" position and flip toggle switch to "Jog". It is located on the left-hand side of the tool.



9. Loosen the wing nuts and adjust each guard to conform to and lightly pinch the pad against the pipe. Tighten wing nuts to secure guards in position.

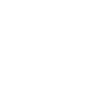
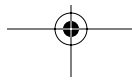

VE268

PIPE STABILIZER ADJUSTMENT

The Series VE268 pipe stabilizer is designed to prevent pipe sway on 8" through 12" nominal IPS pipe sizes. This applies to short as well as long pipes. Once the stabilizer is adjusted for a selected pipe size and wall thickness, it does not require further adjustment on that size and thickness. Pipe of the same size and thickness may be moved in and out of the tool without retracting stabilizer.

1. Make sure proper roll set is on the tool for the pipe size and material to be grooved. Rolls are marked with pipe size, part number and are color coded for pipe material for your convenience. See Tool Rating and Roll Selection charts on pages 37 and 38.



10. Remove the guard setting pad. Store the pad on the hook provided.



11. Prepare to support pipe and flip toggle switch to "Normal Operation". Arm/upper roll assembly will return to its upper position and pipe will release.

CAUTION

- Use the "Jog" mode only for pre-operation adjustments of the tool and roll changes.
- Always return switch to "Normal Operation" at the completion of the pre-operation adjustments.
- When tool is left in "Jog" mode with power on, pipe gradually releases which may result in pipe falling out of tool.

Failure to follow this instruction may cause personal injury, product or property damage.

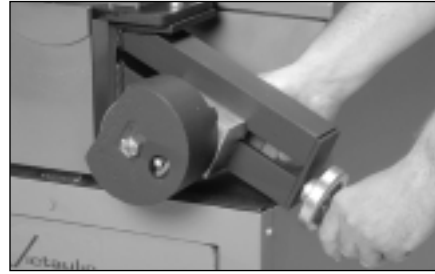

2. Loosen locking handle. With the hand-wheel, retract stabilizer roller to clear pipe when inserted onto lower roll.



3. Insert a piece of pipe of the correct size and schedule to be grooved over the lower roll with the pipe end against the lower roll backstop flange.

VE268



4. Set the main power switch to the “ON” position and flip toggle switch to “Jog”. It is located on the left-hand side of the enclosure.



5. With operator on the switch side of the machine, use the safety foot switch to energize the tool motor, bringing the upper roll down into firm contact with pipe. Withdraw foot from safety foot switch.

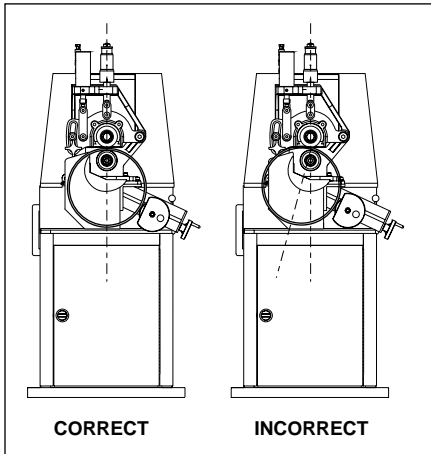

Figure 4

6. Advance stabilizer roller inward with hand-wheel to the position indicated in Figure 4, then tighten locking handle.

! CAUTION

Do not adjust stabilizer to push pipe to the left and off center from the rolls. Doing so will cause increased pipe end flare and shorten roller life.

- Assembly of couplings on pipe exceeding Maximum Allowable Flare, Column 8 in the Roll Groove Specifications charts, pages 39 - 42, may prevent assembly of couplings pad-to-pad, allowing possible pipe separation and result in property damage.
- Also, joint leakage may result due to excessive gasket distortion/damage.



7. Prepare to support pipe and flip toggle switch to “Normal Operation”. Arm/upper roll assembly will return to its upper position and pipe will release.

! CAUTION

- Use the “Jog” mode only for pre-operation adjustments of the tool and roll changes.
- Always return switch to “Normal Operation” at the completion of the pre-operation adjustments.
- When tool is left in “Jog” mode with power on, pipe gradually releases which may result in pipe falling out of tool.

Failure to follow this instruction may cause minor personal injury, product or property damage.

8. Complete the **Pre-Operation Adjustments** and groove the pipe (see Grooving Operation, page 17.) Observe the stabilizer roller while grooving. It should remain in contact with the pipe most of the time and the pipe should rotate smoothly without swaying from side to side. If not, advance stabilizer roller further inward. Retest and make further adjustments as necessary. Remember, do not adjust stabilizer too far inward as it will skew the pipe to the left and possibly result in excessive pipe end flaring.

VE268

**GROOVE DIAMETER STOP
ADJUSTMENT/SELECTOR
VALVE SETTING**

The groove diameter stop must be adjusted for each pipe size or change in wall thickness. Groove diameter, identified as the "C" dimension for each pipe size, is listed under Roll Groove Specifications, pages 39 - 42.

NOTICE

To perform the following adjustments, use several short scrap sections of pipe (but not shorter than what is recommended in Table 1, page 9) of the proper material, diameter and thickness to be grooved.

To achieve proper diameter:

1. Determine the diameter and thickness of the pipe to be grooved. (See the Dimensions charts on page 43.)



2. Locate the proper diameter and thickness on the pipe size indicator on the depth stop. It is rotatable for easy viewing.



3. Back off the depth adjuster lock. Align the depth adjuster with the proper diameter and thickness. Lock the depth adjuster in position with the depth adjuster lock.

NOTICE

The markings provide an approximate groove diameter adjustment and are not exact groove diameter settings. Variations in actual pipe O.D.'s and wall thicknesses make it impossible to calibrate the diameter stop exactly.



4. Set the selector valve on the front of the tool to the color that matches the pipe size and schedule number color (red or black) on the pipe size indicator.

NOTICE

The selector valve only affects the maximum pressure at which the upper roll forms the groove. It does not affect the rate at which the upper roll advances toward the pipe at the start of grooving nor the rate at which the roll retracts from the pipe at the completion of the groove.

Ram pressure during the formation of the groove can have a significant effect on pipe end flaring. The above recommended settings will produce accurate grooves in most situations. When operating in the high ram pressure or "red" setting, if excessive pipe flaring or stalling of drive motor occurs, changing the selector valve setting to low or "black" will usually correct the condition.



5. Insert the pipe over the lower roll with the pipe end against the lower roll backstop flange.
6. Prepare a trial groove. To do so, follow the Grooving Operation procedures outlined on pages 17 - 21.

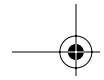

VE268

WARNING

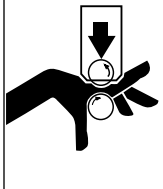

Grooving rolls can crush or cut fingers and hands.

- Be sure guard is properly adjusted before grooving pipe.
- Keep hands away from grooving rolls and stabilizer wheel.

- Never reach inside pipe end or across the tool or pipe during operation.
- Always groove pipe in a clockwise direction only.
- Never groove pipe shorter than what is recommended.
- Never wear loose clothing, loose gloves, or jewelry while operating tool.



7. After a trial groove is prepared and the pipe is removed from the tool, carefully check the groove diameter ("C" dimension), as charted on pages 39 - 42 under Roll Groove Specifications. The "C" dimension is best checked with a pipe tape. It may also be checked with a vernier caliper or narrow land micrometer at two locations, 90 degrees apart, around the groove. The average reading must be within the required groove diameter specification.

CAUTION

- The "C" dimension (groove diameter) must always conform to specifications under Roll Groove Specifications, pages 39 - 42, to ensure proper joint performance.

Failure to do so could result in personal injury, property damage, improper installation, joint leakage or joint failure.

8. If groove diameter ("C" dimension) is not within tolerance, the diameter stop must be adjusted to obtain the proper dimension. To adjust for a **smaller groove diameter**, turn the depth adjuster and depth adjuster lock **counterclockwise**. To adjust for a **bigger groove diameter**, turn adjuster and depth adjuster lock **clockwise**. A quarter turn either way will change the groove diameter adjustment by **0.031"** (0.125" per full turn).

9. Prepare another trial groove and check the groove diameter again. Repeat steps 7 and 8 until the groove diameter is within specification. If excessive pipe flaring or stalling of the drive motor occurs, even when roll grooving with the reduced ram pressure ("black" selector valve setting), the following adjustment of the Ram Speed Control Valve is required.

ADJUSTING THE RAM SPEED CONTROL VALVE

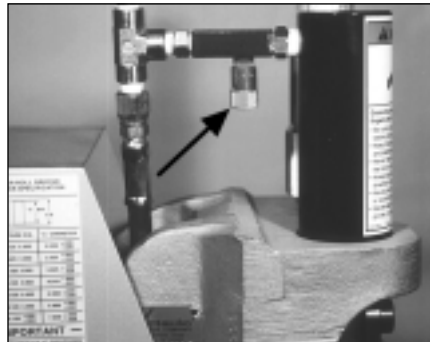

The Ram Speed Control Valve adjustment is set at maximum speed when the tool leaves the factory, which is satisfactory for the roll grooving of most pipes within the tool's rating. When excessive pipe flare or tool "stalling" exists, proceed as follows:



1. Set power switch to the "OFF" position.

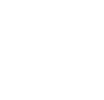
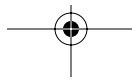

VE268



2. Make sure the selector valve on the front of the tool is adjusted to the “black” setting.



3. Turn the ram speed control valve knob **clockwise** two to three revolutions to reduce flow.

NOTE: The Ram Speed Control Valve features both color coding and numerical readout for convenience.



4. Set power switch to the “ON” position and make sure the toggle switch is on the “Normal Operation” position.

5. Follow the Grooving Operation procedures outlined in this manual and prepare another trial groove.

6. If pipe flare is still found to be excessive or the tool still stalls, repeat Steps 1 through 5.

NOTE: The ram speed control valve affects both the rate at which the upper roll forms the groove and the rate at which the upper roll advances to contact the pipe. The rate at which the upper roll retracts from the pipe will not be affected. The use of the travel stop on the pipe sizes shown

on pages 26 and 27 of this manual will limit how far the upper roll retracts which minimizes the distance and time it must move down to groove the pipe.

⚠ CAUTION

To prevent damage to the tool’s hydraulics:

- Never operate the tool with the flow control valve completely closed.
- Never attempt to roll groove pipe while making an adjustment to the flow control valve.
- Never make adjustments to the flow control valve while the tool is under pressure.

Failure to follow these instructions may cause serious personal injury, property damage, improper installation, joint leakage or joint failure.

GROOVING OPERATION

⚠ CAUTION

- Vic-Easy Series VE268 tools are designed **ONLY** for roll grooving pipe of the sizes, materials and wall thicknesses outlined under Tool Rating and Roll Selection, pages 37 and 38.

Grooving pipe other than that recommended will result in improper pipe end configuration or improper groove dimensions for applying Victaulic products.

Before grooving, make sure you have followed all instructions in:

- “Tool Setup” on page 7
- “Grooving Rolls” on page 9
- “Pipe Preparation” on page 9
- “Groovable Pipe Lengths” on page 9
- “Roll Guard Adjustment” on page 11
- “Pipe Stabilizer Adjustment” on page 13
- “Groove Diameter Stop Adjustment/ Selector Valve Setting” on page 15
- “Adjusting the Ram Speed Control Valve” on page 16

⚠ WARNING



- Before operating tool, review all safety precautions on page 4.

Failure to do so may result in serious personal injury.

VE268

⚠ DANGER



- To reduce the risk of electric shock, check the electrical source for proper grounding. Failure to do so could result in death or serious personal injury.

GROOVING WITH PIPE IN ROLLER-TYPE PIPE SUPPORT



1. Set power switch to the "ON" position.



2. Momentarily depress safety foot switch to be certain tool is operational.



3. If the upper roll is not in the full up position, flip toggle switch on the left side of the tool to the normal operation position.

⚠ WARNING

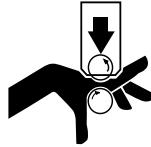

Grooving rolls can crush or cut fingers and hands.

- Be sure guard is properly adjusted before grooving pipe.
 - Keep hands away from grooving rolls and stabilizer wheel.
 - Never reach inside pipe end or across the tool or pipe during operation.
- Always groove pipe in a clockwise direction only.
 - Never groove pipe shorter than what is recommended.
 - Never wear loose clothing, loose gloves, or jewelry while operating tool.



4. Insert pipe onto lower roll up against back-stop flange of lower roll. Remove hands from pipe.



5. Operator should be positioned as shown.

VE268



6. To initiate grooving, depress and hold down the safety foot switch to start tool. This will produce rotation of the lower roll. The upper roll will move down to contact the pipe, starting the pipe rotation and grooving process.



7. Let the grooving continue until the depth adjuster lock comes into full, firm contact with the top of the tool body. Continue pipe rotation for several revolutions to ensure groove completion.



8. Withdraw foot from safety foot switch and remove pipe from tool.

! WARNING

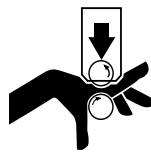

Grooving rolls can crush or cut fingers and hands.

- Do not place hand(s) inside end of pipe to pull pipe out of tool or place hand(s) in area of grooving rolls or stabilizer roller.

NOTICE

Groove diameter should be correct for the diameter and wall thickness of pipe for which it was set under Groove Diameter Stop Adjustment. Groove diameter should be checked and adjusted as necessary to ensure grooves are within specification

GROOVING SHORT PIPE LENGTHS



1. Set power switch to the "ON" position.



2. Momentarily depress safety foot switch to be certain tool is operational.

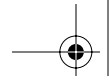

VE268



3. If the upper roll is not in the full up position, flip toggle switch on the left side of the tool to the normal operation position.



5. The upper roll will move down to contact the pipe, starting the pipe rotation and grooving process. Remove hands from pipe.

WARNING

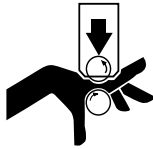

Grooving rolls can crush or cut fingers and hands.

- Be sure guard is properly adjusted before grooving pipe.
- Loading and unloading pipe will place your hands close to the rollers.
- Never reach inside pipe end or across the tool or pipe during operation.

- Never groove pipe shorter than what is recommended in Table 1 on page 9.
- Always groove pipe in a clockwise direction.
- Never wear loose clothing, loose gloves or jewelry while operating tool.



6. Let the grooving continue until the depth adjuster lock comes into full, firm contact with the top of the tool body. Continue pipe rotation for several revolutions to ensure groove completion.



7. Prepare to support pipe and withdraw foot from foot switch. Remove pipe from tool.



4. Insert pipe onto lower roll square against backstop flange. Hold pipe in a level position without resting pipe on lower roll. Depress and hold down the safety foot switch, while maintaining pipe in this position. This will produce rotation of the lower roll.

WARNING

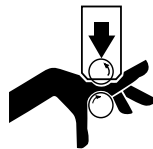

Grooving rolls can crush or cut fingers and hands.

- Do not place hand(s) inside end of pipe to pull pipe out of tool or place hand(s) in area of grooving rolls or stabilizer roller.

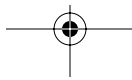

VE268

NOTICE

Groove diameter should be correct for the diameter and wall thickness of pipe for which it was set under Groove Diameter Stop Adjustment. Groove diameter should be checked and adjusted as necessary to ensure grooves are within specification.

ROLL CHANGING

NOTICE

Vic-Easy Series 268 roll grooving tools are designed for fast, easy grooving. Rolls accommodate several pipe sizes (refer to Tool Rating and Roll Selection charts on pages 37 and 38) eliminating the need for frequent roll changes. When a different size range is encountered or different grooving styles are required, the grooving rolls must be changed and Pre-Operation Adjustments performed. Also, different pipe materials may require that the rolls be changed. See Tool Rating and Roll Selection charts on pages 37 and 38 for proper roll selection.

TRAVEL STOP KNOB REMOVAL PROCEDURE FOR 3/4", 1 - 1 1/2" & 2 - 3 1/2" IPS SIZES AND 2 - 6" COPPER ONLY

NOTICE

Arm/upper roller assembly must return to its maximum upper position prior to changing rolls. The 3/8" - 16 UNC threaded travel stop knob limits the travel of the arm.



1. Set power switch to the "ON" position and flip the toggle switch to the "Jog" position.



2. Depress and hold down safety foot switch until the arm/upper roller assembly is not in contact with the threaded portion of the travel stop knob. Withdraw foot from the safety foot switch.



3. Unscrew the travel stop knob from the tool body by turning counterclockwise. Store it in the cabinet.



4. Flip toggle switch to "Normal Operation." Arm/upper roller assembly will return to its upper position. Set power switch to the "OFF" position.

WARNING

- Always turn off power before making any tool adjustments. Accidental start up of tool may result in serious personal injury.

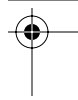
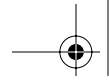

VE268

ROLL REMOVAL PROCEDURE



1. Set power switch to the "OFF" position.

⚠ WARNING

- Always turn off power before making any tool adjustments.
- Accidental start up of tool may result in serious personal injury.

LOWER ROLL – ¾" & 1 - 1½" SIZES



1. With a wrench fitted on the square end of the lower roll, loosen and remove lower roll as an assembly by turning **clockwise**. Store lower roll in the cabinet.

NOTICE

The ¾" & 1 - 1½" lower roll assembly is held in position with left hand threads and must be loosened by turning clockwise.

LOWER ROLL – 2" AND LARGER SIZES



1. With a wrench, loosen and remove (thin) jam nut, securing large nut on lower roll shaft.

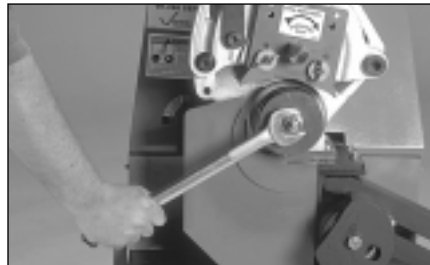

2. With a wrench, loosen large nut on lower shaft and back off ¼" without removing.

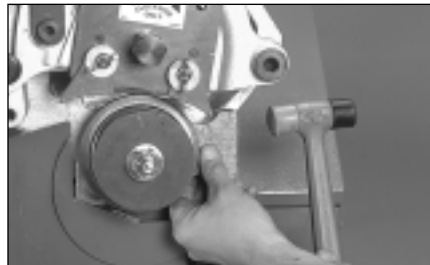

3. To loosen lower roll from tapered lower roll shaft, use the aluminum wedge supplied with tool. Place wedge behind lower roll and hit with a hammer to break roll loose from taper. **Do not use a hammer on the roll.**

⚠ WARNING



Hammering rolls can cause serious personal injury due to fragmentation.

- Always wear eye protection.
- Always use supplied aluminum wedge for roll removal.
- Always use soft faced hammers with aluminum wedge.
- Never strike rolls directly for any reason.

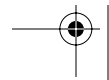
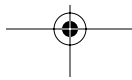
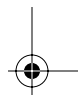

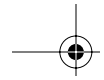

VE268

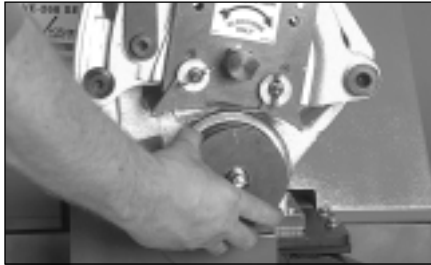

4. Remove the nut, washer and roll and store in the cabinet.



2. Pull the upper roll assembly off. Store in the cabinet.

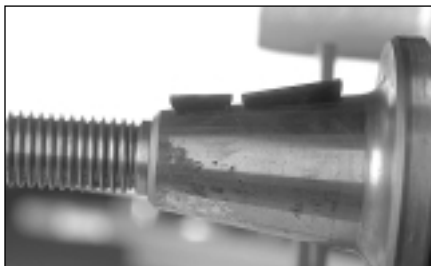

ARBOR SHAFT REMOVAL PROCEDURE

See Tool Rating and Roll Selection charts on pages 37 and 38 for information on available grooving rolls.

1. Remove roll set from tool. Refer to Roll Removal Procedure for 2" and larger sizes on page 22.

NOTICE
Be careful not to lose the Woodruff keys. They should remain in the 2 - 12" arbor. Inspect the Woodruff keys and replace if damaged. Spare Woodruff keys have been placed in the Instruction Manual.



UPPER ROLL – ALL SIZES



1. With a wrench, loosen and remove upper roll bolt. Place on a clean surface.

2. With a wrench fitted on exposed hex portion of stud, fully loosen the stud by turning **counterclockwise**. The arbor should move outwards as the stud is loosened.



3. Once the stud has stopped moving the arbor outwards, pull the arbor shaft and stud assembly out and store in the cabinet.

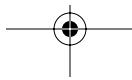

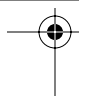
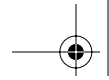

VE268

NOTICE

In the event of insufficient lubrication, the arbor shaft could become difficult to remove from the main shaft. The arbor shaft features three (3) 1/4" - 20 UNC tapped holes so that jack bolts can be used to push out the arbor shaft.



CAUTION

- Never operate tool with the jack bolts installed in the arbor shaft.
- Failure to follow this instruction may result in personal injury, product or property damage.

ROLL INSTALLATION PROCEDURE

See Tool Rating and Roll Selection charts on pages 37 and 38 for information on available grooving rolls.

UPPER ROLL – ALL SIZES

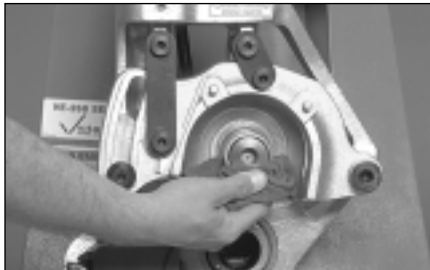

1. Clean all shaft surfaces and roll bores of any dirt and/or scale before installation.



2. While upper roll is removed from tool, inspect the roller bearing inside for contamination, proper lubrication and movement. Also inspect guards for wear and freedom of adjustment. Make repairs/replacements as necessary.



3. Carefully slide desired upper roll assembly onto upper shaft with red plate facing out. Loosen guards, if necessary, to make installation easier. Make sure red plate engages the two pins on the arm and that it then contacts the front of the upper roll shaft.

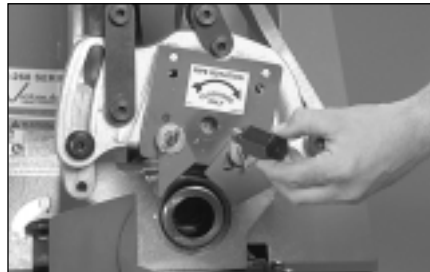

4. Insert upper roll bolt and tighten securely with a wrench.



5. Lubricate upper roll bearing. Refer to Maintenance section (Recommended Lubricants, page 32) for additional information.

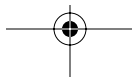
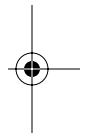

VE268

LOWER ROLLS – ¾" & 1 - 1½"

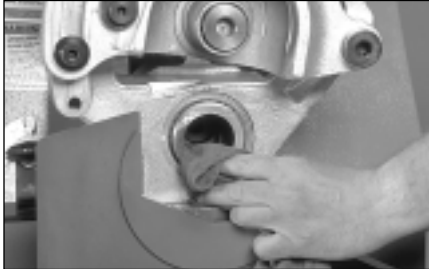

1. Clean the bore of the main shaft and the roll assembly parts with a soft cloth.



2. Lightly lubricate the roll assembly parts with the proper lubricant (Dow Corning G-n mechanical assembly spray, supplied with tool and available from the Victaulic Tool Company.)



3. Carefully insert the lower roll and adapter assembly into the main shaft, making sure it is fully seated. It may be necessary to rotate the adapter to align its square back end with the main shaft. Tighten the lower roll by turning **counterclockwise**.

ARBOR SHAFT INSTALLATION PROCEDURE

2" AND LARGER SIZES



1. Clean the bore of the main shaft and the arbor shaft assembly parts with a soft cloth.

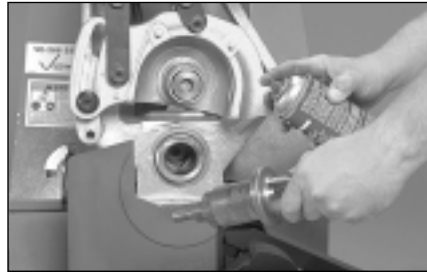

2. Lightly lubricate the roll assembly parts with the proper lubricant (Dow Corning G-n mechanical assembly spray, supplied with tool and available from the Victaulic Tool Company.)

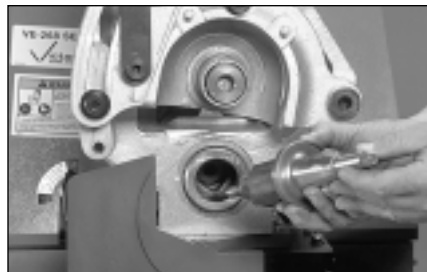

3. Carefully insert the arbor shaft assembly into the main shaft, making sure it is fully seated. It may be necessary to rotate the adapter to align its square back end with the main shaft. Tighten the remaining stud by turning the exposed hex portion of the stud **clockwise**.

VE268

ROLL INSTALLATION PROCEDURE

LOWER ROLL – 2" AND LARGER SIZES

NOTICE

Arbor shaft must be installed prior to installing 2" and larger size lower rolls. Refer to instructions at left.



1. Place lower roll onto arbor shaft. Reposition guards, if necessary, to make assembly easier. Make sure lower roll fits fully onto arbor shaft with keys and keyway in alignment.



2. Install flat washer and large nut on threaded arbor stud, in front of lower roll, and tighten securely with a wrench.



3. Install (thin) jam nut on threaded arbor stud and tighten securely, with a wrench, against large nut.

Roll installation is complete. Before grooving, make sure all **Pre-Operation Adjustments** (pages 9 - 17) are reviewed and followed.

CAUTION

- Always return switch to "Normal Operation" at the completion of the pre-operation adjustments.
- Use the "Jog" mode only for pre-operation adjustments of the tool.
- When tool is left in "Jog" mode with power on, pipe gradually releases which may result in pipe falling out of tool.

Failure to follow this instruction may cause minor personal injury, product or property damage.

TRAVEL STOP KNOB INSTALLATION PROCEDURE FOR ¾", 1 - 1½" & 2 - 3½" IPS AND COPPER ONLY

The travel stop knob is used to limit upper roll/arm retraction such that upper roll travel distance is minimized and which improves grooving productivity.



NOTICE

The ¾" - 16 UNC travel stop knob never replaces the ½" - 13 UNC socket head cap screw that limits the arm/upper roller return travel.



1. Insert a piece of ¾ - 3½" pipe to be grooved over the lower roll with the pipe against the lower roll backstop flange.

VE268



2. Flip toggle switch to the "Jog" position.



3. With operator on the switch side of the machine, use the foot safety switch to energize the tool motor, bringing the upper roll down into firm contact with the pipe. Withdraw foot from safety foot switch.

NOTICE

Lower roll will rotate when the safety foot switch is engaged.



4. Make sure guards are properly adjusted per the Roll Guard Adjustment Procedure on page 11.



5. Thread the aluminum travel stop knob into the $\frac{3}{8}$ " - 16 UNC tapped hole located on the slide face.



6. Prepare to support pipe and flip toggle switch to "Normal Operation". Arm/upper roll assembly will return to its upper position and pipe will release.

NOTICE

When roll grooving other pipe sizes, the hand knob is not to be used. Store this knob in the cabinet when not in use.

VE268

MAINTENANCE

GENERAL

This manual provides information on keeping tools in top operating condition and guidance in making repairs when it becomes necessary.

Replacement parts, applicable only to these tools, should be ordered from Victaulic Tool Company to ensure proper operation of the tool. All parts are FOB Easton, Pennsylvania, at the price in effect at the time of ordering.

NOTICE

Remember that preventative maintenance during operation will pay for itself in safety, repair and operating savings.

⚠ DANGER



- Before performing any repair or maintenance, disconnect the tool from the electrical source to prevent accidental start up of tool, unless instructed otherwise in this manual.

Failure to do so could result in death or serious personal injury.

LUBRICATION

After every eight hours of operation, lubricate the machine. Always lubricate upper roll bearings when rolls are changed.

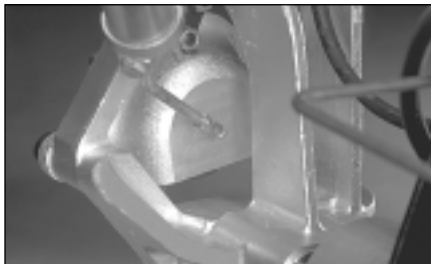

1. Grease upper roll bearing at fitting provided as shown with a No. 2EP Lithium base grease. See Recommended Lubricants on page 32.



2. Grease main shaft bearings at grease fitting with a No. 2EP Lithium base grease. See Recommended Lubricants on page 32.



3. Lubricate the linkage mechanisms, the arm pivot point, and the arm sliding surfaces. A heavy duty spray lubricant may be used or apply grease by hand. See Recommended Lubricants on page 32.

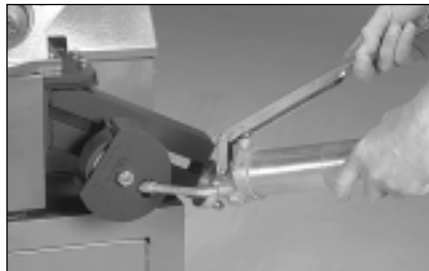

4. Lubricate the stabilizer wheel with a No. 2EP Lithium base grease. See Recommended Lubricants on page 32.

VE268

HYDRAULIC SYSTEMS

Check the hydraulic oil level at least every 50 hours of operation, preferably before start up. The oil level should be no lower than $\frac{3}{4}$ " from the top of the tank. Fill with recommended hydraulic oil (refer to page 32) to no higher than $\frac{1}{2}$ " from the top of the tank. The $\frac{1}{2}$ " clearance is needed for the expansion of the hydraulic fluid when higher temperatures are reached.

NOTICE

Be sure to use a recommended hydraulic oil.

Change the hydraulic oil and filter every 4000 hours of operation.

TO DRAIN THE OIL

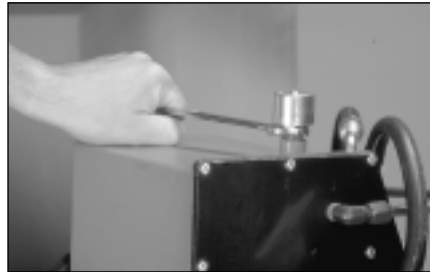

1. Remove the hydraulic breather cap atop the hydraulic tank.



2. Remove the drain plug in the hydraulic line next to the tank. Permit the oil to drain into a $1\frac{1}{2}$ gallon or larger container.

TO REMOVE THE FILTER

- 1.** With an oil filter wrench, loosen the filter.
- 2.** By hand, remove the filter.

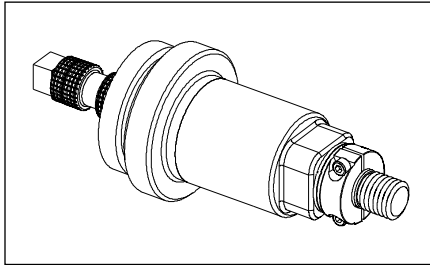

5. After every 40 hours of operation, clean and lubricate the $\frac{3}{4}$ " and 1 - $\frac{1}{2}$ " lower roll sets.

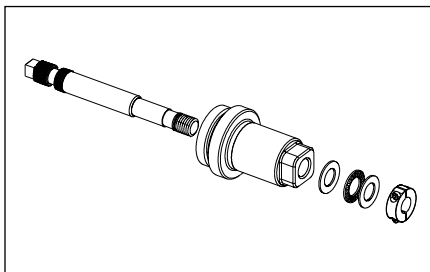

6. Remove the cap screws and disassemble the two-piece collar. Remove both the collar and needle bearing and washers.

7. Remove lower roll from arbor. Clean the $\frac{3}{4}$ " and 1 - $\frac{1}{2}$ " lower roll and lightly lubricate with the proper lubricant (Dow Corning G-n mechanical assembly spray, supplied with tool and available from Victaulic Tool Company.)

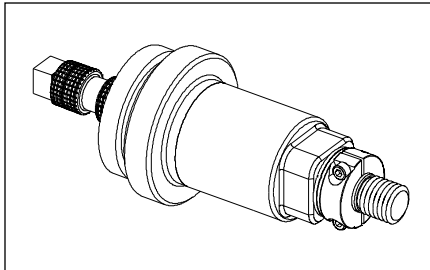

8. Reassemble the $\frac{3}{4}$ " and 1 - $\frac{1}{2}$ " lower roll and lubricate the needle bearing as well.

VE268

TO INSTALL THE FILTER

1. With hydraulic oil, lightly lubricate the filter gasket.
2. Fill the new filter with oil and install it hand tight. (Replacement filter part number: Victaulic # NH08000002)

TO REFILL THE OIL

1. Replace the drain plug.
2. Fill the hydraulic tank with a recommended hydraulic oil (refer to page 32) to a level 1/2" below the top of the tank.

HYDRAULIC FLUID BLEEDING PROCEDURE

1. Fill the hydraulic tank with a recommended hydraulic oil (refer to page 32) to a level 1/2" below the top of the tank.



2. Remove the plug from the tee fitting near the hydraulic cylinder.



3. Install the bleeder tube (supplied with tool), hand tight, into the tee fitting.



4. Remove breather cap. Insert the end of the bleeder tube (clear hose) into the tank so the tube end is submerged in the hydraulic fluid.

5. Connect the tool to its proper power supply.
6. Set power switch to the "ON" position.
7. Flip toggle switch to the "Jog" position.

⚠ WARNING

- Lower roll will rotate during Step 8. Avoid contact with lower roll.
- Failure to do so may result in serious personal injury.



8. Depress the safety foot switch and observe the hydraulic fluid start flowing through the bleeder tube. The fluid should have air bubbles in it. Continue running the fluid through the bleeder tube for at least five minutes. While doing this, lightly tap on all of the steel hydraulic tubes to free air trapped on tubing inside walls. Also, manually depress and release the hydraulic cylinder ram several times to free trapped air inside cylinder. Do this while the fluid is flowing through the bleeder tube. Once the fluid is flowing through the bleeder tube without any air bubbles, continue running for at least two to three minutes. Release foot switch.

VE268

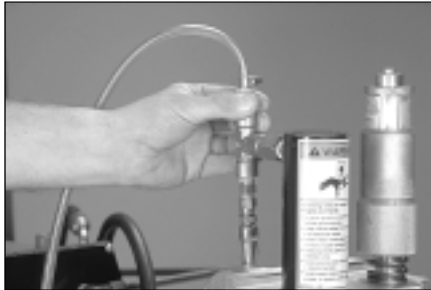

9. Remove the bleeder tube from the tee fitting and tank. Install the plug into the tee fitting. Be certain air is not allowed back into the tee fitting while doing this.



10. Fill the hydraulic fluid level to $\frac{1}{2}$ " from the top of the tank and install breather.



11. Set the depth stop on the tool to obtain a $\frac{1}{4}$ " gap between the depth stop and top of tool body.



12. Set the valve on the front of the tool to the "black" position.

13. Flip toggle switch to "Normal Operation" position.

⚠ WARNING

- Lower roll will rotate during Step 14. Avoid contact with lower roll.

Failure to do so may result in serious personal injury.



14. Depress the foot switch and observe the hydraulic ram motion. It should move down $\frac{1}{4}$ " fairly rapidly. Release the foot switch and the hydraulic ram should return to its full up position. Repeat this several times.

15. Set the valve on the front of the tool to the "red" position and repeat Step 14.

16. If the slide does not move fairly rapidly in the downward direction, repeat Steps 2 - 15.

17. Set power switch to the "OFF" position.

VE268

GEAR REDUCER OIL LEVEL CHECK



Figure 5

1. Remove oil level plug from gear reducer (see Figure 5). Oil level should be even with bottom of hole.
2. To add oil, remove oil fill/level plug from side of gear reducer and fill to proper level (see Figure 5).
3. Install plug(s).

GEAR REDUCERS OIL CAPACITY: 60 OZ.

RECOMMENDED LUBRICANTS

BEARING AND SLIDE GREASE

General Purpose E.P. Lithium Base Grease

<u>MANUFACTURER</u>	<u>PRODUCT</u>
• Amoco Oil	Amolith Grease #2EP
• Arco Petroleum Prod. Co.	Litholine HEP 2
• Ashland Oil, Inc./Valvoline Oil Co.	Multi-Lube Lith. EP Grease
• Exxon Co., USA	Lidok EP 2
• Gulf Oil Corp.	Gulfcrown Grease EP#2
• Kendall Refining Co.	L-426
• Lubriplate	No. 630-2
• Mobil Oil Corp.	Mobilux EP2
• Pennzoil Prod. Co.	Pennlith EP 712 Lube
• Shell Oil Co.	Alvania EP2
• Sun Refining	Sun Prestige 742 EP
• Texaco Inc.	Multifak EP2

GEAR OIL

See tag on Gear Reducer.

HYDRAULIC OIL

High Pressure Anti-Wear
Hydraulic Oil ISO Grade 32

<u>MANUFACTURER</u>	<u>PRODUCT</u>
• Amoco Oil	Rykon Oil #32
• Arco Petroleum Products Co.	Duro AW 32
• Ashland Oil, Inc./Valvoline Oil Co.	AW Oil #15
• Exxon Co., USA	Nuto H 32
• Gulf Oil Corp.	Harmony 32 AW
• Kendall Refining Co.	Kenoil R&O AW-32
• Lubriplate	HO-O
• Mobil Oil Corp.	Mobil DTE 24
• Pennzoil Products Co.	AW 32 Hyd. Oil/Penreco Oil 32
• Shell Oil Co.	Tellus 32
• Sun Refining	Survis 706, 816 WR
• Texaco Inc.	Rando Oil HD 32

PARTS ORDERING INFORMATION

When ordering parts, the following information is necessary for the Victaulic Tool Company to process the order promptly and send the correct part(s):

- (1) Tool Model Number: VE268.
- (2) Tool Serial Number: The serial number can be found on the side of the tool name plate.
- (3) (Quantity), Item Number, Part Number and Description: (1) #101, R-101-268-MCI, Main Shaft. Refer to Victaulic repair parts list, RP-268.
- (4) Where to send the part (s):
Company name
Address
- (5) To whose attention to send the part(s).
Person's name
- (6) Purchase Order Number
- (7) Billing Address

Order parts from the nearest Victaulic sales office. Consult the back page of this Instructions Manual for the nearest Victaulic sales office.

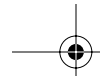

VE268

ACCESSORIES

VICTAULIC ADJUSTABLE PIPE STANDS

VAPS 112



Victaulic Model 112, a portable, adjustable, roller type, four-leg pipe stand for use with Series VE268 and other Victaulic roll grooving tools, is available from Victaulic. Ball transfer rollers, adjustable for pipe from 3/4 - 12", will accommodate linear and rotational movement. Turnstile design permits easy swivel for grooving both pipe ends. Contact Victaulic for details.

VAPS 224



Also available is Victaulic Model 224. It has features similar to Model 112. It is suitable for pipe sizes from 2 - 24". Consult Victaulic for details.

OPTIONAL ROLLS

See Tool Rating and Roll Selection charts on pages 37 and 38 for rolls for different materials and groove specifications.

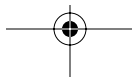

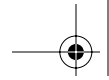

VE268

TROUBLESHOOTING

Problem	Possible Cause	Solution
Pipe will not stay in grooving rolls.	Incorrect pipe positioning.	For long pipes, pipe is not in correct position for tracking. See Pre-Operation Adjustments. For short pipes, pipe is not positioned level and square with lower roll. See Grooving Short Pipe Lengths.
Pipe stops rotating during grooving.	Rust or dirt has built up on lower roll. Excessive ram pressure. Ram speed control valve requires adjustment. Worn grooving rolls. Main breaker has tripped and/or thermal overloads in motor starter tripped. Woodruff key(s) under 2" and larger lower roll are broken or missing.	Remove accumulation from lower roll with stiff wire brush. Reduce ram pressure by turning valve to the "black" position. Turn the ram speed control valve knob clockwise two or three revolutions to reduce flow. Inspect lower roll for worn knurls, replace if worn. Reset breaker and/or motor starter thermal units. Remove lower roll and insert punch tool in key removal hole(s). Press out the remains of broken key(s) and install new Woodruff #605 and/or #608 key(s). Install lower roll, see Roll Changing.
Pipe flare is excessive.	Excessive ram pressure. Ram speed control valve requires adjustment. Pipe support adjusted too high. Tool is tilted forward. Incorrect pipe support positioning, pipe is "overtracking". Stabilizer is adjusted too far inward.	Reduce ram pressure by turning valve to the "black" position. Turn the ram speed control valve knob clockwise two or three revolutions to reduce flow. Check pipe levelness. See Pipe Support section. Check tool levelness. See Tool Setup section. Move pipe support to right. See Pipe Support section. Back off stabilizer to the furthest point where it still stabilizes pipe effectively. See Stabilizer Adjustment section.

Continued on next page.

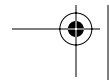
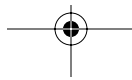

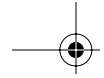

VE268



TROUBLESHOOTING

Problem	Possible Cause	Solution
Pipe sways or vibrates from side to side.	Incorrect stabilizer adjustment.	Move stabilizer in or out until pipe rotates smoothly.
While grooving, loud squeaks echo through the pipe.	Incorrect pipe support positioning, pipe is "overtracking". Pipe not square cut. Pipe is rubbing excessively hard on lower roll flange.	Move pipe support to the right. See Pipe Support section. Cut pipe end squarely. Remove pipe from tool and apply a film of grease to the face of the lower roll flange as needed.
During grooving, loud thumps or bangs occur about once every revolution of the pipe.	Pipe has a pronounced weld seam.	Grind welds flush with pipe surface inside and out 2" back from pipe end.
Pump won't start or lower roll won't rotate.	Main power is off. Thermal units tripped. Fuses blown or main breaker is tripped.	Turn on main power. Reset thermal units. Check fuses and replace as necessary, or reset breaker.
Tool comes up to operating pressure excessively slow.	Air in hydraulic system.	Bleed air from hydraulic system.

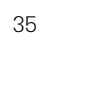
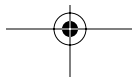
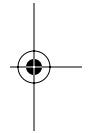

VE268

ELECTRICAL SCHEMATIC

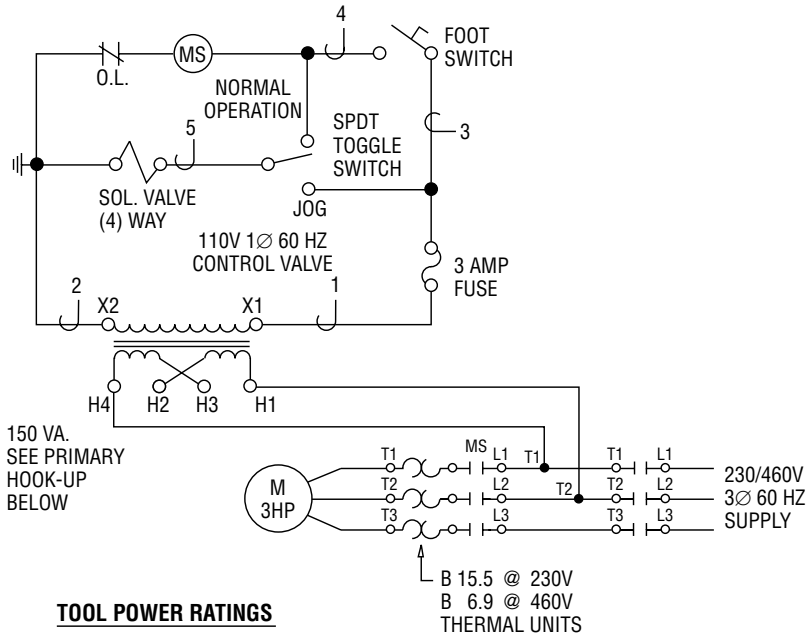

TOOL POWER RATINGS

230 OR 460 VOLT 3 PHASE 60 HZ
8.8 AMP FULL LOAD @ 230 VOLTS
4.4 AMP FULL LOAD @ 460 VOLTS

INCOMING POWER MUST BE SHORT
CIRCUIT PROTECTED BY BREAKER
OR FUSES.

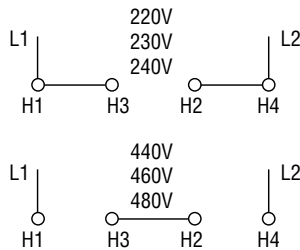

TRANSFORMER CONNECTIONS

VE268

TOOL RATING AND ROLL SELECTION
STANDARD AND "ES" ROLLS - COLOR CODED BLACK

2468-2B

PIPE SIZE Nom. Inches Actual mm	1		2		3		4		Standard Roll Nos.	"ES" Roll Nos.
	Nominal Dimensions - Inches/mm									
	Steel Pipe Wall Thickness		Stain. Steel Pipe Wall Thickness		Alum. Pipe Wall Thickness		PVC Plastic Pipe Wall Thickness			
	Min.	Max.	Min.	Max.	Min.	Max.	Min.	Max.		
¾ 26,9	0.065 1,7	0.113 2,9	0.065 1,7	0.113 2,9	0.065 1,7	0.113 2,9	0.113 2,9	0.113 2,9	Lower Roll R900268L013 Upper Roll R9A0268U024	NOT APPLICABLE
1 33,7	0.065 1,7	0.133 3,4	0.065 1,7	0.133 3,4	0.065 1,7	0.133 3,4	0.133 3,4	0.133 3,4	Lower Roll R901268L024 Upper Roll R9A0268U024	NOT APPLICABLE
1¼ 42,4	0.065 1,7	0.140 3,6	0.065 1,7	0.140 3,6	0.065 1,7	0.140 3,6	0.140 3,6	0.140 3,6		
1½ 48,3	0.065 1,7	0.145 3,7	0.065 1,7	0.145 3,7	0.065 1,7	0.145 3,7	0.145 3,7	0.145 3,7		
2 60,3	0.065 1,7	0.154 3,9	0.154 3,9	0.154 3,9	0.065 1,7	0.154 3,9	0.154 3,9	0.154 3,9		
2½ 73,0	0.083 2,1	0.203 5,2	0.203 5,2	0.203 5,2	0.083 2,1	0.203 5,2	0.203 5,2	0.276 7,0	Lower Roll R902272L03	Lower Roll RZ02272L03
3 88,9	0.083 2,1	0.216 5,5	0.216 5,5	0.216 5,5	0.083 2,1	0.216 5,5	0.216 5,5	0.300 7,6	Upper Roll R9A2272U06	Upper Roll RZA2272U03
3½ 101,6	0.083 2,1	0.226 5,7	0.226 5,7	0.226 5,7	0.083 2,1	0.226 5,7	0.226 5,7	0.318 8,1		
4 114,3	0.083 2,1	0.237 6,0	0.237 6,0	0.237 6,0	0.083 2,1	0.237 6,0	0.237 6,0	0.337 8,6		
4½ 127,0	0.095 2,4	0.237 6,0	0.237 6,0	0.237 6,0	0.095 2,4	0.237 6,0	-	-	Lower Roll R904272L06	Lower Roll RZ04272L06
5 141,3	0.109 2,8	0.258 6,6	0.258 6,6	0.258 6,6	0.109 2,8	0.258 6,6	0.258 6,6	0.375 9,5	Upper Roll R9A2272U06	Upper Roll RZA4272U06
6 O.D. 152,4	0.109 2,8	0.258 6,6	0.258 6,6	0.258 6,6	0.109 2,8	0.258 6,6	-	-		
6 168,3	0.109 2,8	0.280 7,1	0.280 7,1	0.280 7,1	0.109 2,8	0.280 7,1	0.280 7,1	0.432 11,0		
8 O.D. 203,2	0.109 2,8	0.322 8,2	0.250 6,4	0.322 8,2	0.109 2,8	0.322 8,2	0.322 8,2	0.322 8,2		
8 219,1	0.109 2,8	0.322 8,2	0.250 6,4	0.322 8,2	0.109 2,8	0.322 8,2	0.322 8,2	0.322 8,2	Lower Roll R908272L12	Lower Roll RZ08272L12
10 273,0	0.134 3,4	0.250 6,4	0.250 6,4	0.250 6,4	0.134 3,4	0.250 6,4	0.365 9,3	0.365 9,3	Upper Roll R9A8272U12	Upper Roll RZA8272U12
12 323,9	0.156 4,0	0.250 6,4	0.250 6,4	0.250 6,4	0.156 4,0	0.250 6,4	0.406 10,3	0.406 10,3		

STANDARD AND "ES" ROLLS NOTES:

COLUMN 1: Maximum ratings on steel are limited to pipe of 180 BHN (Brinell Hardness Number) and less.

COLUMN 2: Types 304/304L and 316/316L

COLUMN 3: Alloys 6061-T4 and 6063-T4

COLUMN 4: PVC Type I Grade I - PVC1120; PVC Type I Grade II - PVC1220; PVC Type II Grade I - PVC2116

All wall thicknesses are nominal minimum and maximum.

The following O.D. sized pipe also may be roll grooved: 3" O.D., 4¼" O.D., 5¼" O.D., 5½" O.D., 6¼" O.D., 6½" O.D., 8" O.D. and 12" O.D.
 Contact Victaulic for details.

VE268

ROLLS FOR SCHEDULE 5S AND 10S STAINLESS STEEL PIPE (RX ROLLS) – COLOR CODED SILVER

0886-3A

SIZE Nominal Inches Actual mm	Nominal Dimensions – Inches/mm		RX Roll Nos.
	Stainless Steel Pipe † Wall Thickness		
	Schedule 5S	Schedule 10S	
2 60.3	0.065 1.7	0.109 2.8	Lower Roll RX02272L03 Upper Roll RXA2272U06
2½ 73.0	0.083 2.1	0.120 3.0	
3 88.9	0.083 2.1	0.120 3.0	
3½ 101.6	0.083 2.1	0.120 3.0	Lower Roll RX04272L06 Upper Roll RXA2272U06
4 114.3	0.083 2.1	0.120 3.0	
5 141.3	0.109 2.8	0.134 3.4	
6 168.3	0.109 2.8	0.134 3.4	Lower Roll RX08272L12 Upper Roll RXA8272U12
8 219.1	0.109 2.8	0.148 3.8	
10 273.0	0.134 3.4	0.165 4.2	
12 323.9	0.156 4.0	0.180 4.6	

All wall thicknesses are nominal minimum and maximum.

† Types 304/304L and 316/316L.

The following O.D. sized pipe also may be roll grooved: 3" O.D., 4¼" O.D., 5¼" O.D., 5½" O.D., 6" O.D., 6¼" O.D., 6½" O.D., 8" O.D. and 12" O.D. Contact Victaulic for details.

ROLLS FOR COPPER TUBING – COLOR CODED COPPER †

0886-4A

SIZE Nominal Inches Actual mm	Nominal Dimensions – Inches/mm		Copper Roll Nos.
	Copper Tubing Wall Thickness		
	Min.	Max.	
2 54.0	0.042 1.1	0.083 2.1	Lower Roll RR02272L06 Upper Roll RRA2272U06
2½ 66.7	0.065 1.7	0.095 2.4	
3 79.4	0.045 1.1	0.109 2.8	
4 104.8	0.058 1.5	0.134 3.4	Lower Roll RR08272L08 Upper Roll RRA8272U08
5 130.2	0.072 1.8	0.160 4.1	
6 155.6	0.083 2.1	0.192 4.9	
8 206.4	0.109 2.8	0.271 6.9	

† Drawn copper tubing – DWV, ASTM B306 - Type "M", ASTM B88 – Type "L", ASTM B88 – Type "K", ASTM B88.

All wall thicknesses are nominal minimum and maximum.

VE268

ROLL GROOVE SPECIFICATIONS

**STEEL PIPE AND ALL MATERIALS
GROOVED WITH STANDARD AND RX ROLLS**

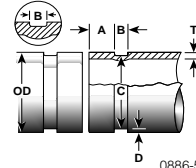

0886-5A

1 SIZE Nom. Inches Actual mm	2 Dimensions – Inches/millimeters										7 Min. Allow. Wall Thk. T	8 Max. Allow. Flare Dia.
	Pipe Outside Diameter			3 Gasket Seat A ±0.03 ±0.76	4 Groove Width B ±0.03 ±0.76	5 Groove Diameter C		6 Groove Depth D (ref.)				
	Basic	Tolerance + –				Basic	Tol. +0.000 +0.00					
¾ 26.7	1.050 26.9	0.010 0.25	0.010 0.25	0.625 15.88	0.281 7.14	0.938 23.83	-0.015 -0.38	0.056 1.42	0.065 1.65	1.15 29.2		
1 33.4	1.315 33.4	0.013 0.33	0.013 0.33	0.625 15.88	0.281 7.14	1.190 30.23	-0.015 -0.38	0.063 1.60	0.065 1.65	1.43 36.3		
1¼ 42.2	1.660 42.2	0.016 0.41	0.016 0.41	0.625 15.88	0.281 7.14	1.535 38.99	-0.015 -0.38	0.063 1.60	0.065 1.65	1.77 45.0		
1½ 48.3	1.900 48.3	0.019 0.48	0.019 0.48	0.625 15.88	0.281 7.14	1.775 45.09	-0.015 -0.38	0.063 1.60	0.065 1.65	2.01 51.1		
2 60.3	2.375 60.3	0.024 0.61	0.024 0.61	0.625 15.88	0.344 8.74	2.250 57.15	-0.015 -0.38	0.063 1.60	0.065 1.65	2.48 63.0		
2½ 73.0	2.875 73.0	0.029 0.74	0.029 0.74	0.625 15.88	0.344 8.74	2.720 69.09	-0.018 -0.46	0.078 1.98	0.083 2.11	2.98 75.7		
3 O.D. 76.1	3.000 76.1	0.030 0.76	0.030 0.76	0.625 15.88	0.344 8.74	2.845 72.26	-0.018 -0.46	0.078 1.98	0.083 2.11	3.10 78.7		
3 88.9	3.500 88.9	0.035 0.89	0.031 0.79	0.625 15.88	0.344 8.74	3.344 84.94	-0.018 -0.46	0.078 1.98	0.083 2.11	3.60 91.4		
3½ 101.6	4.000 101.6	0.040 1.02	0.031 0.79	0.625 15.88	0.344 8.74	3.834 97.38	-0.020 -0.51	0.083 2.11	0.083 2.11	4.10 104.1		
4¼ O.D. 108.0	4.250 108.0	0.043 1.04	0.031 0.79	0.625 15.88	0.344 8.74	4.084 103.73	-0.020 -0.51	0.083 2.11	0.083 2.11	4.35 110.5		
4 114.3	4.500 114.3	0.045 1.14	0.031 0.79	0.625 15.88	0.344 8.74	4.334 110.08	-0.020 -0.51	0.083 2.11	0.083 2.11	4.60 116.8		
4½ 127.0	5.000 127.0	0.050 1.27	0.031 0.79	0.625 15.88	0.344 8.74	4.834 122.78	-0.020 -0.51	0.083 2.11	0.095 2.41	5.10 129.5		
5¼ O.D. 133.0	5.250 133.0	0.053 1.34	0.031 0.79	0.625 15.88	0.344 8.74	5.084 129.13	-0.020 -0.51	0.083 2.11	0.109 2.77	5.35 135.9		
5½ O.D. 139.7	5.500 139.7	0.056 1.42	0.031 0.79	0.625 15.88	0.344 8.74	5.334 135.48	-0.020 -0.51	0.083 2.11	0.109 2.77	5.60 142.2		
5 141.3	5.563 141.3	0.056 1.42	0.031 0.79	0.625 15.88	0.344 8.74	5.395 137.03	-0.022 -0.56	0.084 2.13	0.109 2.77	5.66 143.8		
6 O.D. 152.4	6.000 152.4	0.056 1.42	0.031 0.79	0.625 15.88	0.344 8.74	5.830 148.08	-0.022 -0.56	0.085 2.16	0.109 2.77	6.10 154.9		
6¼ O.D. 159.0	6.250 159.0	0.063 1.60	0.031 0.79	0.625 15.88	0.344 8.74	6.032 153.21	-0.030 -0.56	0.085 2.16	0.109 2.77	6.35 161.3		
6½ O.D. 165.1	6.500 165.1	0.063 1.60	0.031 0.79	0.625 15.88	0.344 8.74	6.330 160.78	-0.022 -0.56	0.085 2.16	0.109 2.77	6.60 167.6		
6 168.3	6.625 168.3	0.063 1.60	0.031 0.79	0.625 15.88	0.344 8.74	6.455 163.96	-0.022 -0.56	0.085 2.16	0.109 2.77	6.73 170.9		
8 O.D. 203.2	8.000 203.2	0.063 1.60	0.031 0.79	0.750 19.05	0.469 11.91	7.816 198.53	-0.025 -0.64	0.092 2.34	0.109 2.77	8.17 207.5		
8 219.1	8.625 219.1	0.063 1.60	0.031 0.79	0.750 19.05	0.469 11.91	8.441 214.40	-0.025 -0.64	0.092 2.34	0.109 2.77	8.80 223.5		

Table continued on next page.

VE268

0886-5A

1	2		3	4	5		6	7	8	
	Dimensions – Inches/millimeters									
	Pipe Outside Diameter			Gasket Seat A ±0.03 ±0.76	Groove Width B ±0.03 ±0.76	Groove Diameter C		Groove Depth D (ref.)	Min. Allow. Wall Thk. T	Max. Allow. Flare Dia.
	SIZE Nom. Inches Actual mm	Basic	Tolerance + -			Basic	Tol. +0.000 +0.00			
10 O.D. 254.0		10.000 254.0	0.063 1.60	0.031 0.79	0.750 19.05			0.469 11.91	9.812 249.23	-0.027 -0.69
10 273.0	10.750 273.0	0.063 1.60	0.031 0.79	0.750 19.05	0.469 11.91	10.562 268.28	-0.027 -0.69	0.094 2.39	0.134 3.40	10.92 277.4
12 O.D. 304.8	12.000 304.8	0.063 1.60	0.031 0.79	0.750 19.05	0.469 11.91	11.781 299.24	-0.030 -0.76	0.109 2.77	0.156 3.96	12.17 309.1
12 323.9	12.750 323.9	0.063 1.60	0.031 0.79	0.750 19.05	0.469 11.91	12.531 318.29	-0.030 -0.76	0.109 2.77	0.156 3.96	12.92 328.2

SEE COLUMN NOTES BELOW.

STANDARD ROLL GROOVE SPECIFICATIONS NOTES (FROM PAGE 39):

COLUMN 1: **Nominal IPS pipe size.**

COLUMN 2: **IPS outside diameter:** The outside diameter of roll grooved pipe shall not vary more than the tolerance listed. For IPS pipe the maximum allowable tolerance from square cut ends is 0.030" for ¾ - 3½"; 0.045" for 4 - 6"; and 0.060" for sizes 8" O.D. and above measured from true square line.

COLUMN 3: **Gasket seat:** The pipe surface shall be free from indentations, roll marks, and projections from the end of the pipe to the groove, to provide a leak-tight seal for the gasket. All loose paint, scale, dirt, chips, grease and rust must be removed. Victaulic recommends that pipe be square cut. When using beveled pipe contact Victaulic for details. Square cut pipe **must** be used with FlushSeal® and EndSeal® gaskets. Gasket seat "A" is measured from the end of the pipe. IMPORTANT: Roll grooving of beveled end pipe may result in unacceptable pipe end flare. See column 8.

COLUMN 4: **Groove width:** Bottom of groove to be free of loose dirt, chips, rust and scale that may interfere with proper coupling assembly. Corners at bottom of groove must be radiused. For IPS steel pipe, .06R on ¾ - 1½", .08R on 2 - 6", .05R on 8" and up.

COLUMN 5: **Groove outside diameter:** The groove must be of uniform depth for the entire pipe circumference. Groove must be maintained within the "C" diameter tolerance listed.

COLUMN 6: **Groove depth:** For reference only. Groove must conform to the groove diameter "C" listed.

COLUMN 7: **Minimum allowable wall thickness:** This is the minimum wall thickness which may be roll grooved – except PVC.

COLUMN 8: **Maximum allowable pipe end flare diameter:** Measured at the most extreme pipe end diameter square cut or beveled.

VE268

DRAWN COPPER TUBING

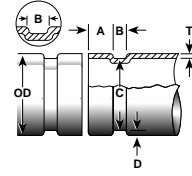

25.06-1A

1 SIZE Nom. In. Actual mm	2 Pipe Outside Diameter Inches/mm		3 Dimensions – Inches/millimeters					
			4 Gasket Seat A ±0.03 ±0.76	5 Groove Width B +0.03/-0.00 +0.76/-0.00	6 Groove Diameter C +0.00	7 Groove Depth (ref.) D	8 Min. Allow. Wall Thick. T	9 Max. Allow. Flare Dia.
	Basic	Tol.						
2 54.0	2.125 54.0	±0.002 ±0.05	0.610 15.5	0.300 7.6	2.029 51.5	0.048 1.2	0.064 1.6	2.220 56.4
2½ 66.7	2.625 66.7	±0.002 ±0.05	0.610 15.5	0.300 7.6	2.525 64.1	0.050 1.2	0.065 1.7	2.720 69.1
3 79.4	3.125 79.4	±0.002 ±0.05	0.610 15.5	0.300 7.6	3.025 76.8	0.050 1.2	DWV	3.220 81.8
4 104.8	4.125 104.8	±0.002 ±0.05	0.610 15.5	0.300 7.6	4.019 102.1	0.053 1.4	DWV	4.220 107.2
5 130.2	5.125 130.2	±0.002 ±0.05	0.610 15.5	0.300 7.6	4.999 127.0	0.053 1.4	DWV	5.220 132.6
6 155.6	6.125 155.6	±0.002 ±0.05	0.610 15.5	0.300 7.6	5.999 152.3	0.063 1.6	DWV	6.220 158.0
8 206.4	8.125 206.4	* *	0.610 15.5	0.300 7.6	7.959 202.2	0.083 2.1	DWV	8.220 208.8

* Tolerances for 8" (200 mm) are +0.002 (0.5 mm), -0.004 (-0.10 mm).

COPPER TUBING ROLL SPECIFICATIONS NOTES

COLUMN 1: **Nominal ASTM B-88 drawn copper tubing size.**

COLUMN 2: **Outside diameter:** The outside diameter of roll grooved tubing shall not vary more than the tolerance listed. The maximum allowable tolerance from square cut ends is 0.030" (0.8 mm) for 2 - 3" (54.0 - 79.4 mm); 0.045" (1.1 mm) for 4 - 6" (104.8 - 155.6 mm), measured from true square line.

COLUMN 3: **Gasket seat:** The tubing surface shall be free from indentations, roll marks, and projections from the end of the tubing to the groove, to provide a leak-tight seat for the gasket. All loose scale, dirt, chips and grease must be removed.

COLUMN 4: **Groove width:** Bottom of groove to be free of loose dirt, chips and scale that may interfere with proper coupling assembly.

COLUMN 5: **Groove outside diameter:** The groove must be uniform depth for the entire tubing circumference. Groove must be maintained within the "C" diameter tolerance listed.

COLUMN 6: **Groove depth:** For reference only. Groove must conform to the groove diameter "C" listed.

COLUMN 7: **Minimum allowable wall thickness:** ASTM B-306 drain waste and vent (DWV) is minimum wall thickness copper tubing which may be roll grooved.

COLUMN 8: **Maximum allowable end flare diameter:** Measured at the most extreme tubing end dia.

VE268

STEEL PIPE AND ALL MATERIALS GROOVED WITH "ES" ROLLS

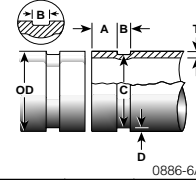

1	2		3		4		5		6	7	8		
	Dimensions – Inches/mm												
	Pipe Outside Diameter				Gasket Seat A		Groove Width B		Groove Dia. C		Grv. Depth (ref.) D	Min. Allow. Wall Thick. T	Max. Allow. Flare Dia.
	SIZE Nom. In. Actual mm	Basic	Tolerance		Basic	Tol. +0.000 +0.00	Basic	Tol. -0.000 -0.00	Basic	Tol. +0.000 +0.00			
2 60.3			2.375 60.3	+0.024 +0.61							-0.024 -0.61	0.572 14.53	-0.020 -0.51
2½ 73.0	2.875 73.0	+0.029 +0.74	-0.029 -0.74	0.572 14.53	-0.020 -0.51	0.250 6.35	+0.015 +0.38	2.720 69.09	-0.018 -0.46	0.078 1.98	0.083 2.11	2.98 75.7	
3 88.9	3.500 88.9	+0.035 +0.89	-0.031 -0.79	0.572 14.53	-0.020 -0.51	0.250 6.35	+0.015 +0.38	3.344 84.94	-0.018 -0.46	0.078 1.98	0.083 2.11	3.60 91.4	
4 114.3	4.500 114.3	+0.045 +1.14	-0.031 -0.79	0.610 15.49	-0.020 -0.51	0.300 7.62	+0.020 +0.51	4.334 110.08	-0.020 -0.51	0.083 2.11	0.083 2.11	4.60 116.8	
6 168.3	6.625 168.3	+0.063 +1.60	-0.031 -0.79	0.610 15.49	-0.020 -0.51	0.300 7.62	+0.020 +0.51	6.455 163.96	-0.022 -0.56	0.085 2.16	0.109 2.77	6.73 170.9	
8 219.1	8.625 219.1	+0.063 +1.60	-0.031 -0.79	0.719 18.26	-0.020 -0.51	0.390 9.91	+0.020 +0.51	8.441 214.40	-0.025 -0.64	0.092 2.34	0.109 2.77	8.80 223.5	
10 273.0	10.750 273.0	+0.063 +1.60	-0.031 -0.79	0.719 18.26	-0.020 -0.51	0.390 9.91	+0.020 +0.51	10.562 268.28	-0.027 -0.69	0.094 2.39	0.134 3.40	10.92 277.4	
12 323.9	12.750 323.9	+0.063 +1.60	-0.031 -0.79	0.719 18.26	-0.020 -0.51	0.390 9.91	+0.020 +0.51	12.531 318.29	-0.030 -0.76	0.109 2.77	0.156 3.96	12.92 328.2	

"ES" ROLL GROOVE SPECIFICATIONS NOTES

COLUMN 1: Nominal IPS pipe size.

COLUMN 2: **IPS outside diameter: Metric (ISO) outside diameter:** The outside diameter of roll grooved pipe shall not vary more than the tolerance listed. For IPS pipe, the maximum allowable tolerance from square cut ends is 0.030" for 2 - 3" (60.3 - 88.9 mm); 0.045" for 4 - 6" (114.3 - 168.3 mm); and 0.060" for sizes 8" (219.1 mm) and above measured from true square line. For (ISO) metric pipe, the maximum allowable tolerance from square cut ends is 0.76 mm for sizes 26.7 mm - 88.9 mm; 1.14 mm for sizes 114.3 mm - 168.3 mm; and 1.52 mm for sizes 219.1 mm and above, measured from the true square line.

COLUMN 3: **Gasket seat:** The pipe surface shall be free from indentations, roll marks, and projections from the end of the pipe to the groove, to provide a leak-tight seal for the gasket. All loose paint, scale, dirt, chips, grease and rust must be removed. Square cut pipe must be used with FlushSeal® and EndSeal® gaskets. Gasket seat "A" is measured from the end of the pipe. IMPORTANT: Roll grooving may result in unacceptable pipe end flare, see Column 8.

COLUMN 4: **Groove width:** Bottom of groove to be free of loose dirt, chips, rust and scale that may interfere with proper coupling assembly. Corners at bottom of roll groove must be radiused. For IPS pipe, 0.04R on 1½ - 12" (48.3 - 323.9 mm). For (ISO) metric pipe, 1.2R mm on 26.7 - 323.9 mm.

COLUMN 5: **Groove outside diameter:** The groove must be uniform depth for the entire pipe circumference. Groove must be maintained within the "C" diameter tolerance listed.

COLUMN 6: **Groove depth:** For reference only. Groove must conform to the groove diameter "C" listed.

COLUMN 7: **Minimum allowable wall thickness:** This is the minimum wall thickness which may be grooved.

COLUMN 8: **Maximum allowable pipe end flare diameter:** Measured at the most extreme pipe end diameter square cut or beveled.

VE268

DIMENSIONS

SEAMLESS AND WELDED STEEL PIPE*

2468-3A

SIZE Nom. In. Actual mm	Pipe O. D. Inches mm	Nominal Wall Thickness – Inches/mm						
		Sch. 5S	Sch. 10S	Sch. 20	Sch. 30	Sch. 40	Sch. STD.	Sch. 80
¾ 26.7	1.050 26.7	0.065 1.7	0.083 2.1	— —	— —	0.113 2.9	0.113 2.9	0.154 3.9
1 33.4	1.315 33.4	0.065 1.7	0.109 2.8	— —	— —	0.133 3.4	0.133 3.4	0.179 4.5
1¼ 42.2	1.660 42.2	0.065 1.7	0.109 2.8	— —	— —	0.140 3.6	0.140 3.6	0.191 4.9
1½ 48.3	1.900 48.3	0.065 1.7	0.109 2.8	— —	— —	0.145 3.7	0.145 3.7	0.200 5.1
2 60.3	2.375 60.3	0.065 1.7	0.109 2.8	— —	— —	0.154 3.9	0.154 3.9	0.218 5.5
2½ 73.0	2.875 73.0	0.083 2.1	0.120 3.0	— —	— —	0.203 5.2	0.203 5.2	0.276 7.0
3 88.9	3.500 88.9	0.083 2.1	0.120 3.0	— —	— —	0.216 5.5	0.216 5.5	0.300 7.6
3½ 101.6	4.000 101.6	0.083 2.1	0.120 3.0	— —	— —	0.226 5.7	0.226 5.7	0.318 8.1
4 114.3	4.500 114.3	0.083 2.1	0.120 3.0	— —	— —	0.237 6.0	0.237 6.0	0.337 8.6
5 141.3	5.563 141.3	0.109 2.8	0.134 3.4	— —	— —	0.258 6.6	0.258 6.6	0.375 9.5
6 168.3	6.625 168.3	0.109 2.8	0.134 3.4	— —	— —	0.280 7.1	0.280 7.1	0.432 11.0
8 219.1	8.625 219.1	0.109 2.8	0.148 3.8	0.250 6.4	0.277 7.0	0.322 8.2	0.322 8.2	0.500 12.7
10 273.0	10.750 273.0	0.134 3.4	0.165 4.2	0.250 6.4	0.307 7.8	0.365 9.3	0.365 9.3	0.594 15.1
12 323.9	12.750 323.9	0.156 4.0	0.180 4.6	0.250 6.4	0.330 8.4	0.406 10.3	0.375 9.5	0.688 17.4

*For reference only. The VE268 cannot groove all schedules of steel pipe in table.

DRAWN COPPER TUBING

0886-8B

SIZE Nominal Inches Actual mm	Pipe O. D. Inches mm	Nominal Wall Thickness – Inches/mm			
		DWV ASTM B-306	Type "M" ASTM B-88	Type "L" ASTM B-88	Type "K" ASTM B-88
2 54.0	2.125 54.0	0.042 1.1	0.058 1.5	0.070 1.8	0.083 2.1
2½ 66.7	2.625 66.7	— —	0.065 1.7	0.080 2	0.095 2.4
3 79.4	3.125 79.4	0.045 1.1	0.072 1.8	0.090 2.3	0.109 2.8
4 104.8	4.125 104.8	0.058 1.5	0.095 2.4	0.110 2.8	0.134 3.4
5 130.2	5.125 130.2	0.072 1.8	0.109 2.8	0.125 3.2	0.160 4.1
6 155.6	6.125 155.6	0.083 2.1	0.122 3.1	0.140 3.6	0.192 4.9
8 206.4	8.125 206.4	0.109 2.8	0.170 4.3	0.200 5.1	0.271 6.9



www.victaulic.com

Victaulic Tool Company
Tool Shipments:
1326 Tatamy Road, Easton, PA 18045-7400
Sales & Lease Payments:
P.O. Box 8588-244, Phila., PA 19171-0244

CUSTOMER CARE CENTER

Phone: 1-800-PICK-VIC (1-800-742-5842)
e-mail: pickvic@victaulic.com

WORLD HEADQUARTERS

P.O. Box 31 • Easton, PA 18044-0031
4901 Kesslersville Road • Easton, PA, USA 18040
Phone: 610/559-3300 • FAX: 610/250-8817

VICTAULIC COMPANY OF AMERICA

P.O. Box 31 • Easton, PA 18044-0031
Phone: 610/559-3300 • Fax: 610/250-8817

**Fire Protection Division
Customer Care Centers**

■ **SOUTHEAST FIRE PROTECTION**

Phone: 877/773-8322 • Fax: 877/776-9769

■ **NORTHEAST FIRE PROTECTION**

Phone: 888/265-0805 • Fax: 888/265-0918

■ **CENTRAL FIRE PROTECTION**

Phone: 888/448-3534 • Fax: 888/448-3595

■ **WESTERN FIRE PROTECTION**

Phone: 877/487-7231 • Fax: 877/487-7232

Victaulic Tool Company

P.O. Box 31 • Easton, PA 18044-0031
Phone: 610/559-3300 • Fax: 610/923-3090

Victaulic Municipal Division

1818 Vultee Street • Allentown, PA 18103
Phone: 610/559-3488 • Fax: 610/923-3170

Victaulic Technical Services Division

1818 Vultee Street • Allentown, PA 18103
Phone: 610/559-3488 • Fax: 610/923-3170

United States Distribution Centers

■ **NORTHEAST**

7 Forge Parkway • Franklin, MA 02038
Cust.Care: 800/742-5842 • Cust. Fax: 888/265-0926

■ **NEW YORK METRO**

4901 Kesslersville Road • Easton, PA 18040
Cust.Care: 800/742-5842 • Cust. Fax: 800/437-6573

■ **SOUTHEAST**

650 Coastline Drive • Yulee, FL 32097
Cust.Care: 800/742-5842 • Cust. Fax: 888/201-3468

■ **ATLANTIC**

166 Thorn Hill Road • Warrendale, PA 15086
Cust.Care: 800/742-5842 • Cust. Fax: 888/201-3517

■ **MIDWEST**

730 Thomas Drive • Bensenville, IL 60106
Cust.Care: 800/742-5842 • Cust. Fax: 888/265-2018

■ **GREAT LAKES**

23107 Commerce Drive • Farmington Hills, MI 48335
Cust.Care: 800/742-5842 • Cust. Fax: 800/564-0119

■ **CENTRAL STATES**

5900 Deramus Avenue • Kansas City, MO 64120
Cust.Care: 800/742-5842 • Cust. Fax: 888/448-3540

■ **MID-CONTINENT**

7177 Railspur Street • Houston, TX 77078
Cust.Care: 800/742-5842 • Cust. Fax: 888/448-3537

■ **PERMIAN BASIN**

2628 Remington Road • Odessa, TX 79763
Local Tel.: 915/332-1489 • Local Fax: 915/332-4924

■ **ROCKY MOUNTAIN**

5045 Paris Street • Denver, CO 80239
Cust.Care: 800/742-5842 • Cust. Fax: 888/448-3528

■ **PACIFIC - NORTH**

22633 83rd Ave. So. • Kent, WA 98032
Cust.Care: 800/742-5842 • Cust. Fax: 888/448-3530

■ **MID-ATLANTIC**

4901 Kesslersville Road • Easton, PA 18040
Cust.Care: 800/742-5842 • Cust. Fax: 800/696-6447

■ **PACIFIC - SOUTH**

20934 So. Santa Fe Ave. • Long Beach, CA 90810
Cust.Care: 800/742-5842 • Cust. Fax: 800/448-3542

VICTAULIC COMPANY OF CANADA

65 Worcester Road • Rexdale, Ontario • Canada M9W 5N7
Phone: 416/675-5575 • FAX: 416/675-5565 • e-mail: viccanda@victaulic.com

Canadian Sales Offices and Service Centers

■ **EASTERN**

975 rue Selkirk • Pointe Claire, PQ H9R 4S4
Phone: 514/426-3500 • FAX: 514/426-2818

■ **ONTARIO - NORTH**

1070 Elisabella Street • Sudbury, ON P3A 5K2
Phone: 705/560-9595 • FAX: 705/560-9490

■ **PACIFIC**

Unit 5, 7560 Vantage Way • Delta, BC V4G 1H1
Phone: 604/940-3301 • FAX: 604/940-3360

■ **ONTARIO - SOUTH**

65 Worcester Road • Rexdale, ON M9W 5N7
Phone: 416/675-5575 • FAX: 416/675-5729

■ **WESTERN**

15353 114th Avenue • Edmonton, AB T5M 3S9
Phone: 780/452-0680 • FAX: 780/452-2430

Victaulic® Factory Representatives and Distributor Stocks Worldwide

Victaulic reserves the right to change product specifications,
designs and standard equipment without notice and without obligation.

© Registered Trademark of Victaulic Company of America © Copyright 1999 Victaulic Company of America Printed in U.S.A.